

DURAPAC

ENGINEERED FOR RELIABILITY

Instruction Manual

Needle Valve Manifold with Transport
Frame. Model – VMN-xM-GF



Maximum Operating Pressure – 10,150 psi



This is a safety alert symbol. It is used to alert you to potential personal injury hazards. Obey all safety messages that follow this symbol to avoid injury or death

1.0 Product Information

DURAPAC – Needle Valve Manifolds with Transport Frames are engineered to meet Industrial Standards for Performance and Safety. The VMN Transport Frames are designed to be used with 10,150 psi hand pumps and power units and offer a convenient solution for operating multiple cylinders from a single input source.

Special skill, knowledge and training may be required for a specific task, and the product may not be suitable for all jobs. The user must ultimately make the decision regarding suitability of the product for any given task and assume the responsibility of safety for all in the work area. Contact a Durapac representative if you are unsure of your manifold valve suitability for a particular application.

2.0 Receiving Instructions

It is recommended prior to use that an inspection be done by qualified personnel and that any missing or damaged parts, decals, warning/safety labels or signs are replaced with Durapac authorized replacement parts only. Any manifold valve that appears to be damaged in any way, is worn, leaking or operates abnormally should be removed from service immediately until such time as repairs can be made. Any manifold valve that has been or suspected to have been subject to a shock load should be removed from service immediately until inspected by a Durapac authorized service center. Owners and operators of this equipment should be aware that the use and subsequent repair of this equipment may require specialized training and knowledge.

3.0 Safety

Save these instructions. For your safety, read and understand the information contained within. The owner and operator should understand this product and safe operating procedures before attempting to use this product. Instructions and safety information should be conveyed in the operator's native language before use of this product is authorized. Make certain that the operator thoroughly understands the inherent dangers associated with the use and misuse of the product. If any doubt exists as to the safe and proper use of this product as outlined in this factory authorized manual, remove from service immediately.



DANGER:

- To avoid personal injury, keep hands and feet away from work area during operation
- **Do NOT** handle pressurized hoses. Escaping oil under pressure can penetrate the skin causing serious injury. If oil is injected under the skin, see a doctor immediately
- Stay clear of loads supported by hydraulics. A cylinder, when used as a load lifting device, should never be used as a load holding device. After the load has been raised or lowered, it must always be supported mechanically

**WARNING:**

- The system operating pressure must not exceed the pressure rating of the lowest rated component in the system. Install pressure gauges in the system to monitor operating pressure. It is your window to what is happening in the system
- Always wear appropriate personal protective equipment (PPE) when operating hydraulic equipment. The operator must take precaution against injury due to failure of the tool or work piece(s)
- **Do NOT** hold or stand directly in line with any hydraulic connections while pressurizing
- **Do NOT** attempt to disconnect hydraulic connections under pressure. Release all line pressure before disconnecting hoses
- All personnel must be clear before lowering load or depressurizing the system
- **Do NOT** attempt to lift a load weighing more than the capacity of the cylinder

**IMPORTANT:**

- If at any stage, the safety related decals become hard to read, these must be replaced
- Minimum age of the operator must be 18 years. The operator must have read and understood all instructions, safety issues, cautions and warnings before starting to operate the equipment. The operator is responsible for this activity towards other persons
- **Do NOT** lift hydraulic equipment by the hoses or couplers. Use the carrying handle or other means of safe transport
- Hydraulic equipment must only be serviced by a qualified hydraulic technician. For repair service, contact the Durapac authorized service center in your area. To protect your warranty, use only high-quality hydraulic oil

**CAUTION:**

- **KEEP HYDRAULIC EQUIPMENT AWAY FROM FLAMES AND HEAT.** Hydraulic fluid can ignite and burn. Excessive heat will soften packings and seals, resulting in fluid leaks. Heat also weakens hose materials and packings. For optimum performance do not expose equipment to temperatures of 150° F (65°C) or higher. Protect all equipment from weld spatter
- No alteration should be made to this device

3.1 Hydraulic Pumps

- **Do** use a gauge or other load measuring instrument to verify load
- **Do NOT** exceed the rated capacity of the pump or any equipment in the system. Burst hazard exists if connection pressure exceeds rated pressure
- **Do NOT** operate the system with bent or damaged couplers or damaged threads
- **Do NOT** subject the pump and its components to shock loads
- Use only Durapac approved accessories and components

- **Do NOT** connect to an application which can return more oil to the reservoir than the pump reservoir can hold
- **Do NOT** connect pump to a hydraulic system that is powered by another pump

3.2 Hydraulic Hoses & Fluid Transmission Lines

- Avoid short runs of straight-line tubing. Straight line runs do not provide for expansion and contraction due to pressure and/or temperature changes
- Reduce stress in tube lines. Long tubing runs should be supported by brackets or clips. Before operating the pump, connections should be tightened securely and leak-free. Over tightening can cause premature thread failure or high-pressure fittings to burst
- Should a hydraulic hose ever rupture, burst or need to be disconnected, immediately shut off the pump and release all pressure. Never attempt to grasp a leaking pressurized hose with your hands. The force of escaping hydraulic fluid can inflict injury
- **Do NOT** subject the hose to potential hazard such as fire, sharp objects, extreme heat or cold or heavy impact
- **Do NOT** allow the hose to kink, twist, curl, crush, cut or bend so tightly that the fluid flow within the hose is blocked or reduced. Periodically inspect the hose for wear
- Hose material and coupler seals must be compatible with the hydraulic fluid used. Hoses also must not come in contact with corrosive materials such as battery acid, creosote-impregnated objects and wet paint. Never paint a coupler or hose

FAILURE TO HEED THESE WARNINGS MAY RESULT IN PERSONAL INJURY AS WELL AS PROPERTY DAMAGE.

4.0 Installation

⚠ IMPORTANT: Always secure threaded port connections with high grade, non-hardening pipe thread sealant. Teflon tape can be used if only one layer of tape is used and it is applied carefully, two threads back, to prevent the tape from being introduced into hydraulic system, which could cause jamming of precision-fit parts

- 4.1 Familiarize yourself with the specifications and illustrations in this owner’s manual. Know your manifold valve, its limitations and how it operates before attempting to use. Refer to the specification chart below or if in doubt, contact a Durapac representative.

Model No.	Type	Description
VMN-2M-GF	Valved Manifold	2 way steel bodied manifold with needle valves 2 x 3/8"-NPT female outlet ports, 1 x 3/8"-NPT female inlet port (centrally located opposite to the 2 outlet ports)
VMN-4M-GF	Valved Manifold	4 way steel bodied manifold with needle valves 4 x 3/8"-NPT female outlet ports, 1 x 3/8"-NPT female inlet port (centrally located opposite to the 4 outlet ports)
VMN-6M-GF	Valved Manifold	6 way steel bodied manifold with needle valves 6 x 3/8"-NPT female outlet ports, 1 x 3/8"-NPT female inlet port (centrally located opposite to the 6 outlet ports)
VMN-8M-GF	Valved Manifold	8 way steel bodied manifold with needle valves 8 x 3/8"-NPT female outlet ports, 1 x 3/8"-NPT female inlet port (centrally located opposite to the 8 outlet ports)

Gauge Adapter & Gauge included with each model

Model No.	Type	Description
FGA-1	Gauge Adapter	3/8"-NPT male x 3/8"-NPT female x 1/4"-NPT female gauge adaptor on angle
PG-63	Gauge	2.48 in diam. 0-14,500 psi / 0-1,000 bar 1/4"-NPT Male

- 4.2 Remove the manifold plug and then connect oil output port to suitable fittings and application/cylinder.

5.0 Operation



IMPORTANT:

- Ensure the VMN manifold frame is placed on level stable ground or platform
- Ensure the hydraulic hoses are rated to 10,150 psi, and always keep body parts away from pressurized hydraulic hoses

5.1 Using a VMN Manifold

- 5.1.1 To close a particular valve and stop oil flow to that line, turn the handle clockwise.
- 5.1.2 To open a particular valve, turn the handle anticlockwise. **Note** the handle load will be greater when there is hydraulic pressure in the valves.
- 5.1.3 Valves can be partially opened to allow throttling of the hydraulic oil flow.

6.0 Maintenance



IMPORTANT:

- Check oil level of pumps regularly
- Use only good quality hydraulic fluid. **Do NOT** use brake fluid, transmission fluid, turbine oil, motor oil, alcohol, glycerin etc. Use of anything other than good quality hydraulic oil will void warranty and damage the pump, hose, and application. We recommend Durapac Hydraulic Oil or equivalent
- Equipment must only be serviced by a qualified hydraulic technician. For repair service, contact your local Durapac authorized service center
- Damage to hydraulic hoses may not be detected during visual inspections. For this reason, Durapac recommends that hydraulic hoses be replaced on a regular basis
- Tighten connections as needed. Use non-hardening pipe thread compound when servicing connections

Dirt, sand, etc. will quickly ruin any hydraulic system. Ensure that couplings are clean and free of foreign matter. After each use, clean couplings and attach dust caps.

Maintenance is required when wear or leakage is noticed. Periodically inspect all components to detect any problem that may require service and maintenance.

6.1 Storage

- 6.1.1 When not in use, depressurize and disconnect the VMN Manifold from the application.
- 6.1.2 Wipe clean thoroughly and store in a clean, dry environment. Avoid temperature extremes.

7.0 Parts Breakdown and List

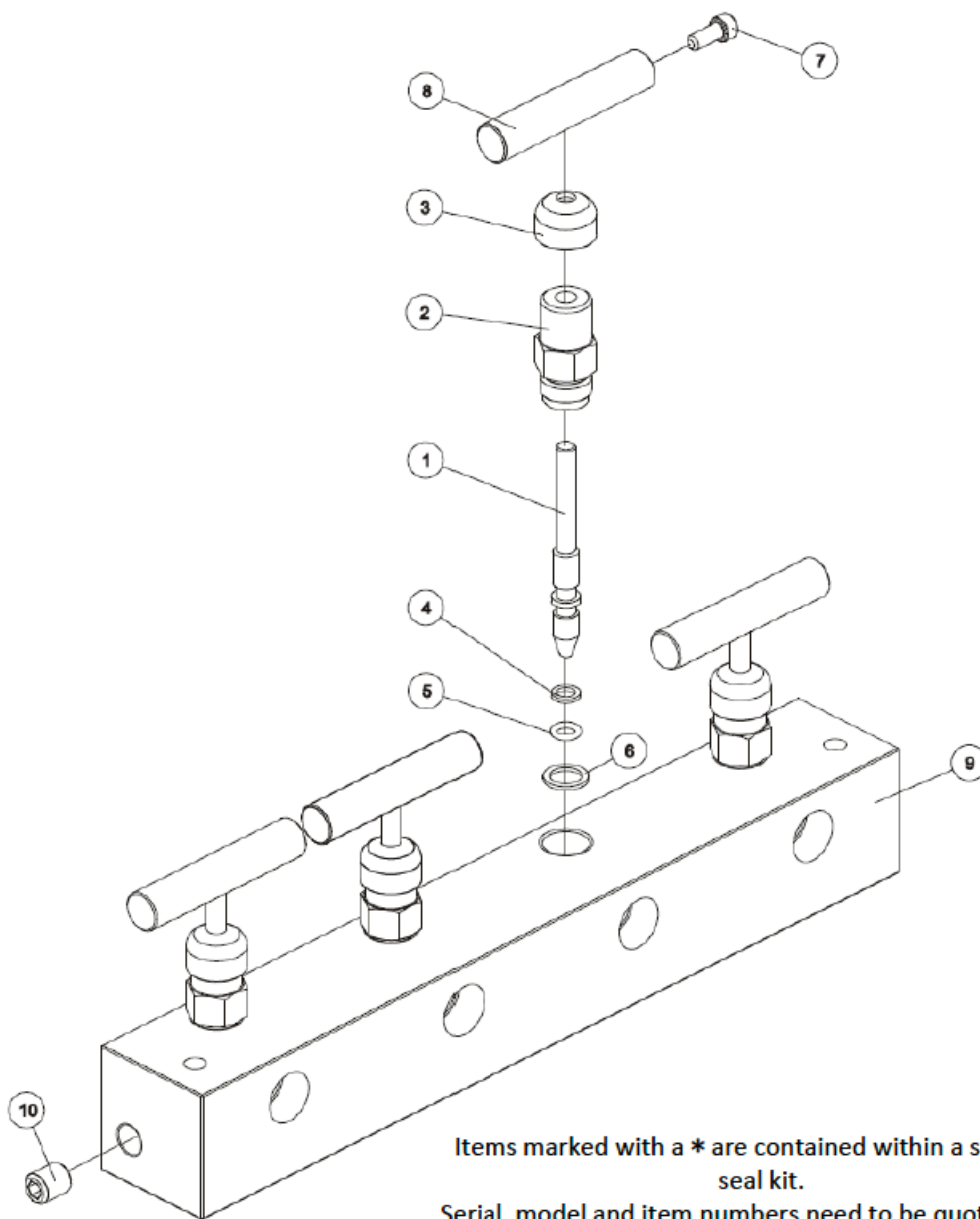

Items marked with a * are contained within a standard seal kit.

Serial, model and item numbers need to be quoted when ordering parts.

Item	Description	Part No.	2 way	4 way	6 way	8 way
			Qty	Qty	Qty	Qty
1	High pressure axle	ZAM2599	2	4	6	8
2	Connector	ZAM2600	2	4	6	8
3	Dust cover	ZAM2601	2	4	6	8
4	Back-up ring*	Seal Kit	2	4	6	8
5	O-ring*		2	4	6	8
6	Copper washer*		2	4	6	8
7	Bolt	ZAM2872	2	4	6	8
8	Handle	ZAM2603	2	4	6	8
9	Frame Assembly (not shown)		VMN-TSR-4	VMN-TSR-4	VMN-TSR-4+2	VMN-TSR-4+4
10	Bolt	ZAM2873	1	2	3	4
*	VMN-x M Seal kits		ZAM2866	ZAM2508	ZAM2867	ZAM2868