

L4176 Rev. E 12/24

Table of Contents:	
Section	Page
1.0 IMPORTANT RECEIVING INSTRUCTIONS	1
2.0 SAFETY	1
3.0 CONFORMANCE TO NATIONAL AND INTERNATIONAL STANDARDS	3
4.0 PRODUCT DESCRIPTION	3
5.0 LIFTING THE CYLINDER	4
6.0 SETUP	4
7.0 AVOIDING SIDE LOAD	5
8.0 OPERATION	5
9.0 INSPECTION, MAINTENANCE & STORAGE	6
10.0 TROUBLESHOOTING	7
11.0 PRODUCT DATA	8

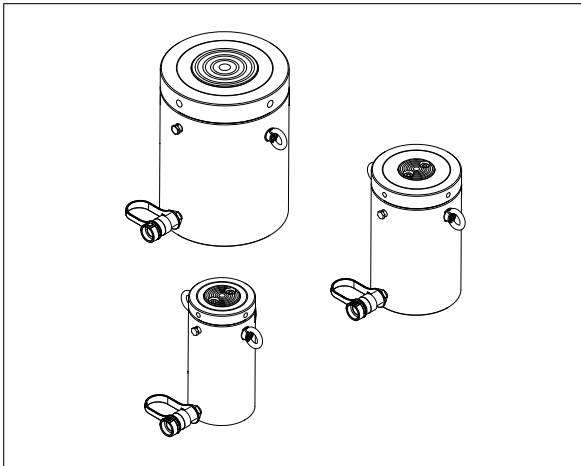

Safety Alert Symbols are used in conjunction with certain Signal Words that call attention to safety messages or property damage messages and designate a degree or level of hazard seriousness. The Signal Words used in this manual are WARNING, CAUTION and NOTICE.

1.0 IMPORTANT RECEIVING INSTRUCTIONS

Visually inspect all components for shipping damage. Shipping damage is not covered by warranty. If shipping damage is found, notify carrier at once. The carrier is responsible for all repair and replacement costs resulting from damage in shipment.

2.0 SAFETY

2.1 Introduction

Read all instructions carefully. Follow all recommended safety precautions to avoid personal injury as well as damage to the product and/or damage to other property. Enerpac cannot be responsible for any damage or injury from unsafe use, lack of maintenance or incorrect operation. Do not remove warning labels, tags, or decals. In the event any questions or concerns arise, contact Enerpac or a local Enerpac distributor for clarification.

If you have never been trained on high-pressure hydraulic safety, consult your distributor or service center for information about an Enerpac Hydraulic Safety Course.

This manual follows a system of safety alert symbols, signal words and safety messages to warn the user of specific hazards. Failure to comply with these warnings could result in death or serious personal injury, as well as damage to the equipment or other property.

The **Safety Alert Symbol** appears throughout this manual. It is used to alert you to potential physical injury hazards. Pay close attention to Safety Alert Symbols and obey all safety messages that follow this symbol to avoid the possibility of death or serious personal injury.

WARNING Indicates a hazardous situation that, if not avoided, **could** result in death or serious personal injury.

CAUTION Indicates a hazardous situation that, if not avoided, **could** result in minor or moderate personal injury.

NOTICE Indicates information considered important, but not hazard related (e.g. messages relating to property damage). Please note that the Safety Alert Symbol will **not** be used with this signal word.

2.2 Hydraulic Cylinder Safety Precautions (HCL-Series)

WARNING

Failure to observe and comply with the following precautions could result in death or serious personal injury. Property damage could also occur.

- Read and completely understand the safety precautions and instructions in this manual before operating the cylinder or preparing it for use. Always follow all safety precautions and instructions, including those that are contained within the procedures of this manual.
- Operating procedures will vary, depending on the system arrangement and the specific components being used. Always read, follow and completely understand all manufacturer's instructions when operating pumps, valves and all other devices used with the cylinders. Follow all safety precautions contained in the manufacturer's manuals.
- Always wear appropriate personal protective equipment (P.P.E.) when operating hydraulic equipment. Be sure to wear eye protection, work gloves and protective clothing.

Use of additional P.P.E. safety items such as dust mask, non-skid safety shoes, hard hat, and hearing protection (used as appropriate for the conditions) will reduce the chance of personal injuries. The use of these items may also be required by local regulations or laws.

- Do not handle pressurized hoses. Escaping oil under pressure can penetrate the skin. If oil is injected under the skin, see a doctor immediately.
- Do not pressurize disconnected couplers.
- Use hydraulic cylinders only in a coupled system. It is acceptable to use a cylinder with a disconnected coupler only if the load is mechanically supported by the cylinder lock nut, and all hydraulic pressure is completely relieved.
- When holding loads, be certain that the lock nut is turned down firmly against the cylinder base so that the load is mechanically supported. Also be sure that all hydraulic pressure is completely relieved.
- Do not remove or disable the pump relief valve.
- Do not remove or disable the cylinder relief valve (if equipped).
- The system operating pressure must not exceed the pressure rating of the lowest rated component in the system.
- Install pressure gauge(s) in the system to monitor operating pressure. It is your window to see what is happening in the system.
- Never set a relief valve to a higher pressure than the maximum rated pressure of the pump and cylinder. If ratings are different, relief valve setting should not exceed the setting of the lowest rated component (pump or cylinder).
- The HCL-Series cylinders are designed for a maximum working pressure of 10150 psi [700 bar]. Do not connect a pump with a higher pressure rating to these cylinders.
- The HCL-Series cylinders contain NO stop ring. Advance the plunger slowly to avoid hydraulically ejecting the plunger from the cylinder base. Stop advancing the plunger immediately if the maximum stroke indicator line appears. Refer to sections 6.5, 8.1 and 8.2 of this manual for additional information and precautions.
- Do not exceed equipment ratings. Never attempt to lift a load weighing more than the rated capacity of the cylinder. Overloading may cause equipment failure and possible personal injury.
- Pressure, capacity and stroke ratings are maximum safety limits. Good practice encourages using only 80% of these ratings.
- Be sure setup is stable before lifting load. Cylinders should be located on a firm and level surface capable of supporting the full load.
- Where applicable, use a cylinder base plate to provide added stability. If desired, the cylinder can be bolted to the base plate, using the bolt holes in the bottom of the cylinder base. (Note: An accessory base plate is available from Enerpac for the HCL-50 Series models. Base plate must be user-fabricated for all other models).
- Do not weld, drill or otherwise modify a cylinder to attach a base plate or other support unless approved in writing by Enerpac Engineering Department. Use only the provided bolt holes.
- Always perform a visual inspection of the cylinder before placing it into operation. If any problems are found, do not use the cylinder. Have the cylinder repaired and tested before it is returned to service.
- Never use a cylinder that is leaking oil. Do not use a cylinder that is damaged, altered or in need of repair.
- Always lift the cylinder using a hoist, crane or other suitable lifting device of sufficient rated capacity. Use only the supplied cylinder lifting eyes to attach the cylinder to the lifting device. Replace any missing or damaged lifting eyes.
- Allow only trained and experienced personnel to supervise and perform lifting and lowering procedures.
- Be certain that no persons are working on or near any cylinders before lifting or lowering of the load begins. Alert all personnel in advance that lifting or lowering is about to occur.
- Use suitable cribbing of rigid construction to hold loads.
- Never use a hydraulic cylinder as a shim or spacer in any lifting or pressing application.
- Be certain that the load is centered and covers the entire plunger saddle surface. Avoid situations where loads are not directly centered on the plunger saddle. The load may slip or fall, causing potential danger.
- Lift only dead weight loads. Avoid lifting live weight loads.
- Be especially careful when lifting loads such as partially filled storage tanks, in which the center of gravity could move or shift during lifting. Be aware that the distribution of some loads can change quickly and without warning.
- Do not use the cylinder to lift people. Do not allow people to be on top of the load during lifting or lowering.
- Keep all personnel clear of the work area while lifting or lowering is in progress. To avoid personal injury, keep hands and feet away from cylinder and load during operation.
- Maintain communication with the operator at all times during lifting or lowering to avoid accidents. Use hand signals, two-way radios or other appropriate forms of communication (as required by applicable laws and regulations) if the load is not visible to the operator.
- Operate pump and valve as required to ensure that the load is lifted and lowered evenly and at a controlled rate.
- Closely watch the load at all times during lifting and lowering. Stop lifting or lowering immediately if the load becomes unstable or appears to be lifting or lowering unevenly.
- Stay clear of loads supported only by hydraulics. As required, follow the lifted load with cribbing.
- Never allow persons to work under or near the load while the load is being supported hydraulically. After the load has been raised or lowered, it always must be blocked mechanically by the cylinder lock nut or via suitable cribbing.
- Always be certain that hydraulic pressure is fully relieved and that the load is fully removed from the cylinder(s) before disconnecting hydraulic hoses, loosening hydraulic fittings, or performing any cylinder disassembly or repair procedures.



Failure to observe and comply with the following precautions could result in minor or moderate personal injury. Property damage could also occur.

- Be careful to avoid damaging hydraulic hoses. Avoid sharp bends and kinks when routing hydraulic hoses. Do not exceed the minimum bend radius specified by the hose manufacturer. Using a bent or kinked hose will cause severe back-pressure. Sharp bends and kinks will internally damage the hose, leading to premature hose failure.
- Do not drop heavy objects on hoses. A sharp impact may cause internal damage to hose wire strands. Applying pressure to a damaged hose may cause it to rupture.
- Do not lift hydraulic equipment by the hoses or couplers. Use the cylinder lifting eyes and appropriately rated lifting equipment.
- Keep hydraulic equipment away from flames and heat. Excessive heat will soften packings and seals, resulting in fluid leaks. Heat also weakens hose materials and packings.
- For optimum performance, do not expose hydraulic equipment to temperatures of 150°F [65°C] or higher. Protect all hydraulic equipment from weld spatter.
- Immediately replace worn or damaged parts with genuine Enerpac parts. Enerpac parts are designed to fit properly and to withstand high loads. Non-Enerpac parts may break or cause the product to malfunction.

NOTICE

- Hydraulic equipment must only be serviced by a qualified hydraulic technician. For repair service, contact the Enerpac Authorized Service Center in your area.
- To help ensure proper operation and best performance, use of Enerpac oil is strongly recommended.

2.3 Crush and Pinch Point Hazard (HCL-Series)

⚠ WARNING Never reach in between the cylinder lock nut and the top of the cylinder base. Serious personal injury can occur if cylinder is retracted and hands, fingers or other body parts are present in this area. See Figure 1.

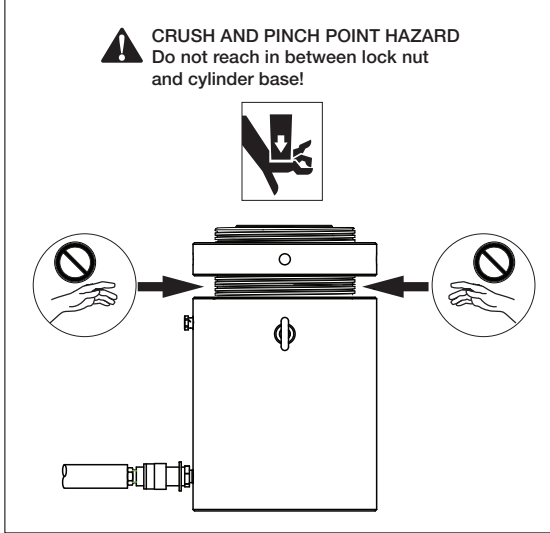

Figure 1, Crush and Pinch Point Hazard

2.4 Additional Safety References

Consult the applicable industry and/or government standards in your country or region for additional safety precautions and work rules applicable to hydraulic cylinders, jacks and other similar lifting equipment.

In the USA, refer to the following publications:

- Code of Federal Regulations - Title 29 Occupational Safety and Health Standards (U.S. Government Publishing Office, 732 North Capitol Street, NW, Washington, DC 20401-0001. www.gpo.gov).
- ASME B30.1 Standards - Jacks (American Society of Mechanical Engineers, Two Park Avenue, New York, NY 10016-5990. www.asme.org).

In the European Union, refer to the standards and directives listed in the product's EU Declaration of Incorporation. A copy of this document is packed separately with the cylinder.

3.0 CONFORMANCE TO NATIONAL AND INTERNATIONAL STANDARDS

CE Enerpac declares that this product has been tested and conforms to applicable standards and is compatible to all CE Requirements. A copy of an EU Declaration of Incorporation is enclosed with each shipment of this product.

4.0 PRODUCT DESCRIPTION

Enerpac HCL-Series lock nut cylinders are an ideal solution for a wide variety of commercial and industrial lifting applications. All HCL-Series cylinders are single-acting, with hydraulic advance and load return. An integral lock nut allows the load to be mechanically supported when hydraulic pressure is relieved.

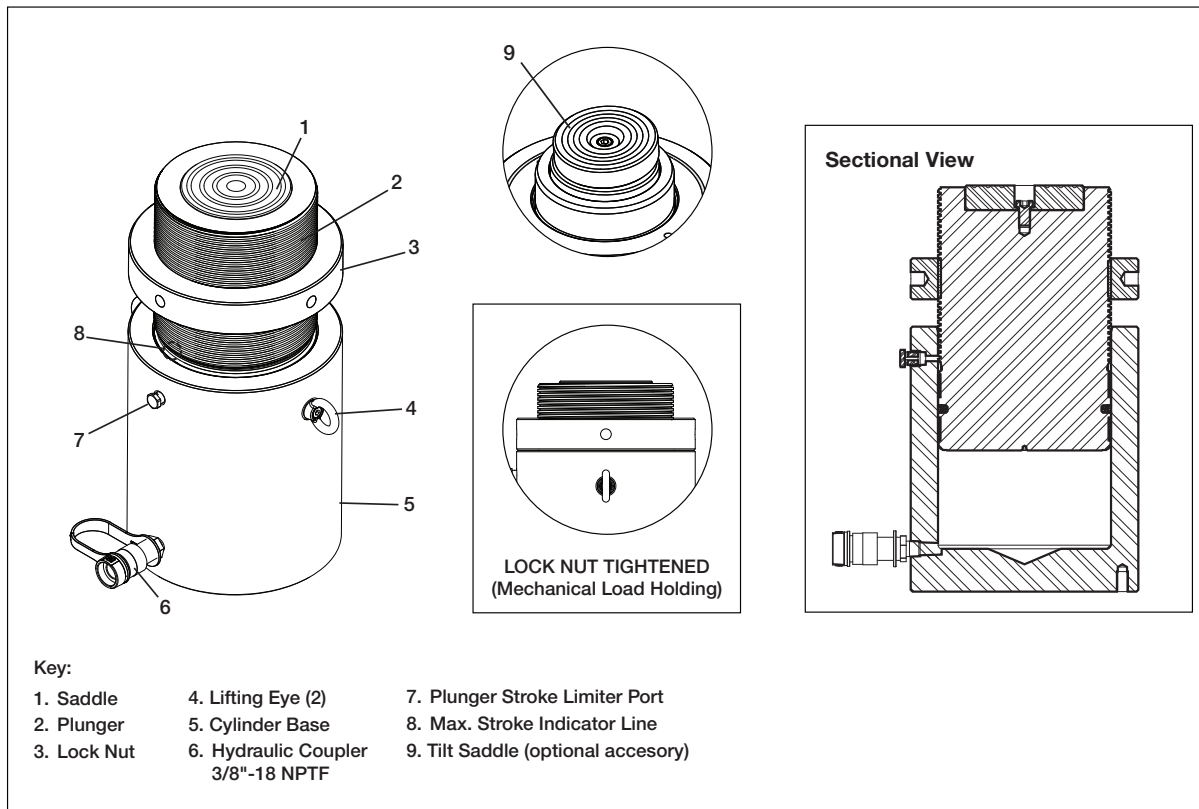

- Key:
- | | | |
|-------------|--------------------------------------|------------------------------------|
| 1. Saddle | 4. Lifting Eye (2) | 7. Plunger Stroke Limiter Port |
| 2. Plunger | 5. Cylinder Base | 8. Max. Stroke Indicator Line |
| 3. Lock Nut | 6. Hydraulic Coupler
3/8"-18 NPTF | 9. Tilt Saddle (optional accesory) |

Figure 2, Major Features and Components

Capacities range from 62 to 1196 US tons [550 to 10644 kN]. Refer to the product data markings on the cylinder base for the capacity rating of your cylinder model.

All standard production HCL-Series cylinders are designed for 10150 psi [700 bar] maximum working pressure.

The HCL-Series cylinders have no stop ring. A maximum stroke indicator line alerts the user when the plunger has reached its full allowable extension. In addition, a built-in stroke limiter port relieves hydraulic pressure in the event that the plunger maximum stroke limit is exceeded.

A hardened grooved saddle is standard equipment on all models. A user-installable tilt saddle is available as an optional accessory.

Refer to Section 11 of this manual for cylinder weights, oil volumes, dimensions and additional specifications.

5.0 LIFTING THE CYLINDER

All HCL-Series cylinders are equipped with two pre-installed lifting eyes. Always use both lifting eyes when hoisting the cylinder.

Lifting straps or chains must be positioned at an angle where they will not interfere with the cylinder base. Use of a spreader bar is recommended. See Figure 3.

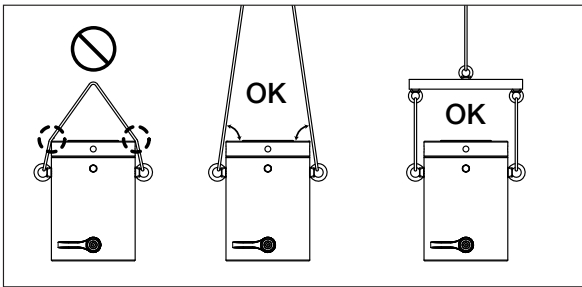

Figure 3, Lifting Arrangements (typical)

6.0 SETUP

6.1 Hydraulic Pump Requirements

Hydraulic pumps are sold separately and are not included with the cylinders.

A hand-operated hydraulic pump can be used to operate a smaller HCL-Series cylinder. However, a large size cylinder (or a series of coupled cylinders) will typically require the use of an electric, air or gas powered hydraulic pump.

Whichever type of pump is used, be certain that the pump reservoir is capable of holding a sufficient amount of hydraulic oil to operate the cylinder (or set of cylinders) to full extension.

The pump must be equipped with a pressure release valve. If greater control is required, a three way directional control valve may be used instead. Both valve types can be either manual or remote operated.

The pump must also be equipped with a separate safety pressure relief valve that opens if the system working pressure exceeds 10150 psi [700 bar]. Verify that the pump safety relief valve is adjusted to the proper setting before using the pump with the cylinder(s).

6.2 Hydraulic Oil Requirements

Use of Enerpac HF Series ISO 32 hydraulic oil is recommended. Enerpac HF oil is available at your local Enerpac Distributor or Authorized Service Center.

NOTICE

- Failure to use the correct oil type (high-quality ISO 32 hydraulic oil) may result in damage to cylinder hydraulic components and will void the product warranty.
- Be sure that the oil is clean. The oil cleanliness should be maintained to a maximum level of 18/16/13 per the ISO 4406 standard. If the oil develops a milky, cloudy or dark appearance, it should be changed immediately.
- To avoid overfilling and possible equipment damage, add oil to the pump reservoir only after all cylinder plungers are completely retracted and system pressure is released.
- When using a hand-operated pump to power the cylinder(s), it is permissible to use a high-quality brand of ISO 15 hydraulic oil. The lower oil viscosity will result in reduced pumping effort, especially in cold weather conditions.

6.3 Tilt Saddle (optional accessory)

The Enerpac CATS Series tilt saddle is available as an optional accessory. If ordered with a HGC or HCR-Series cylinder, the tilt saddle is shipped separately and must be installed on the cylinder before use, as described in the following procedure.

Install the tilt saddle as described in the following steps. Refer to Figure 3 for installation details.

1. Remove the existing center bolt and standard saddle from the plunger bore.
2. Inspect the mating surfaces of the plunger bore and the tilt saddle lower half. Mating surfaces must be free of dust, dirt, moisture or corrosion.
3. Apply service-removable thread locking compound (Loctite® 243 or equivalent) to the threaded stud at the bottom of the tilt saddle.
4. By hand, gently engage the threads of the threaded stud with the threads of the tapped hole at the center of the plunger. Check for free movement. Be sure the stud is not cross-threaded.
5. Rotate the tilt saddle clockwise several turns, until it is fully seated in the plunger bore.

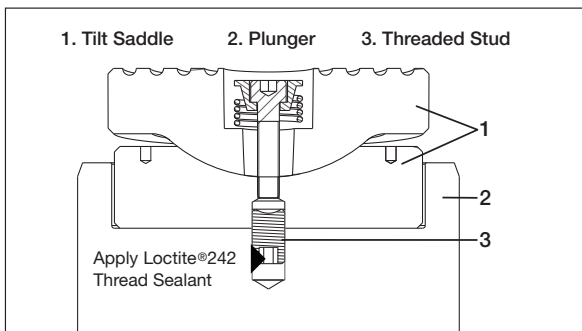

Figure 4, CATS Series Tilt Saddle Accessory (typical)

6.4 Hydraulic Connections

All HCL-Series cylinders are equipped with one 3/8"-18 NPTF female hydraulic coupler. Refer to Figure 2, item 6 for location.

This coupler provides hydraulic flow for both advance and retract functions. It is compatible with all Enerpac HC Series hydraulic hoses.

Be certain that all hose couplers are fully connected, so that hydraulic flow is not blocked or restricted.

All hoses, fittings and other hydraulic components in the circuit must be rated for at least 10150 psi [700 bar] operation.

6.5 Air Removal

Trapped air must be removed from the hydraulic cylinder and hose before placing the system into operation. If multiple cylinders are to be used, it is recommended that air be removed from each cylinder individually. Refer to the following procedure:

1. Place the cylinder in the vertical position, on a flat surface. Be sure that there is no load on the plunger.
2. Verify that the lock nut is positioned at the top of the plunger. This will allow the plunger to be fully retracted during the air removal process.
3. Position the hydraulic pump so it is located *higher* than the cylinder.

⚠ WARNING SLOWLY advance the cylinder plunger during the next step. The HCL-Series cylinder has NO stop ring. The plunger may be hydraulically ejected from the cylinder base if it is advanced too far. Serious personal injury, high pressure oil leakage and property damage could result.

4. Operate pump and valve to SLOWLY advance the plunger. STOP advancing the plunger immediately when the red maximum stroke indicator becomes visible.
5. Relieve hydraulic pressure. Then, manually retract the plunger into the cylinder base until it is fully retracted. Use of a hydraulic pump equipped with a vacuum valve will help aid plunger retraction.
6. Repeat steps 4 and 5 until the plunger advances smoothly.
7. Be sure that the plunger is fully retracted. Then, check the oil level in the pump hydraulic reservoir. If oil level has dropped, add additional oil to the reservoir as required.

NOTICE Refer to Section 6.2 of this document for hydraulic oil requirements. Follow the pump manufacturer's instructions when adding oil to the pump reservoir. To avoid overfilling, be certain that the cylinder plunger is fully retracted before adding any oil.

8. Repeat steps 1 through 7 for all cylinders to be used in the hydraulic circuit.

6.6 Cylinder Base Support

Be certain to provide adequate support for the cylinder base. All HCL-Series cylinders require a flat and stable lifting surface that is capable of supporting the load without settling. A steel plate or steel bars of appropriate size should be placed between the cylinder base and the ground or other lifting surface. See Figure 5.

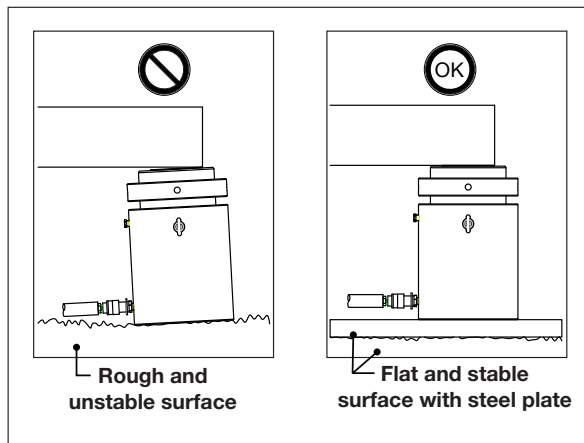

Figure 5, Cylinder Base Support

⚠ CAUTION Use of HCL-Series cylinders on surfaces such as sand, mud or dirt may result in loss of load and/or damage to cylinder.

Base mounting holes are provided on all models. Refer to Section 11.3 for mounting hole locations and dimensions. Mounting bolts are not included with the cylinder and must be provided by the user.

7.0 AVOIDING SIDE LOAD

Plan ahead to eliminate the presence of side load forces (offset loading) when using hydraulic cylinders. Side load can occur as a result of one or more of the following conditions:

- An eccentric load on the plunger.
- A horizontal load on a structure.
- A shifting center of gravity.
- Structure and/or cylinder misalignment.
- Non-synchronized lifting actions.
- Non-stable cylinder base support.

It is understood that some side load will occur in many lifting situations. However, the user should do everything possible to minimize or eliminate this condition.

The possibility of side load can be reduced by ensuring that the cylinder base is located on a flat and hard surface, capable of supporting the cylinder and the load without settling.

To help reduce the effects of side load that cannot be eliminated, use of the CATS Series tilt saddle is strongly recommended.

The CATS series tilt saddle helps compensate for initial misalignment of the load and the saddle surface. It reduces saddle edge loading, which can result in an undesirable off-center load being applied to the plunger. This item is available as an optional accessory for all HCL-Series cylinders. Refer to Section 6.3 for additional information.

8.0 OPERATION

Operation procedures will vary, depending on hydraulic pump type, valve configuration and other factors. For detailed operating instructions and related information, refer to the instruction sheet included with your pump. Also follow the additional instructions and precautions contained in sections 8.1, 8.2 and 8.3 of this manual.

8.1 Operating Precautions

⚠ WARNING

Failure to observe the following instructions and precautions could result in serious personal injury, oil leakage and/or property damage.

- HCL-Series cylinders are NOT equipped with a stop ring. Use these cylinders only in the vertical position with the plunger pointing upwards.
- Advance the plunger slowly. Immediately stop advancing the plunger if the maximum stroke indicator appears or if any oil begins flowing from the plunger stroke limiter port.
- Use extreme caution when using high oil flow pumps with HCL-Series cylinders. The plunger may advance more quickly than expected.
- Stay clear of pinch point area between lock nut and cylinder base at all times (refer to Section 2.3 for additional details).

NOTICE It is mandatory that the operator has a full understanding of all instructions, safety precautions and applicable safety regulations before operating any high force hydraulic equipment. If questions or concerns, contact your local Enerpac Distributor or Authorized Service Center.

8.2 Maximum Stroke Indicator Line and Plunger Stroke Limiter Port

The cylinder plunger contains a maximum stroke indicator line. When this line becomes visible, the plunger has reached its maximum allowable stroke. See Figure 6, item A.

The plunger stroke limiter port (or “overflow port”) is located near the top of the cylinder base. This port is a safety feature, designed to vent hydraulic oil from the cylinder if the plunger exceeds the cylinder’s maximum allowable stroke. See Figure 6, Item B.

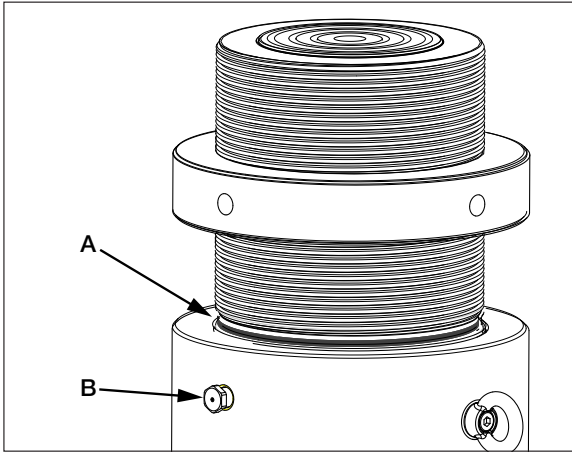

Figure 6, Maximum Stroke Indicator Line (A) and Plunger Stroke Limiter Port (B)

⚠ WARNING

Failure to observe the following instructions and precautions could result in catastrophic failure, erratic operation, high pressure oil leakage and/or damage to cylinder. Death or serious personal injury could result.

STOP advancing the plunger immediately:

- If the maximum stroke indicator line becomes visible.
- If oil flow occurs at the plunger stroke limiter port.

Advancing the cylinder an additional amount could result in the plunger being hydraulically ejected from the cylinder base, especially if the plunger is advanced quickly.

The plunger stroke limiter port contains a specially designed orifice fitting. Never cover or obstruct the orifice fitting passage. Never operate the cylinder with the orifice fitting removed. Never install a pipe plug or any other hydraulic fitting in place of the orifice fitting.

8.3 Operating Instructions

⚠ WARNING To prevent serious personal injury, keep hands, fingers and other body parts clear of pinch point area between lock nut and cylinder base during cylinder operation (refer to Section 2.3 for additional details). Be certain that plunger is not moving when tightening or loosening lock nut.

To advance: Operate pump and valve so that pressurized oil flow is directed in a controlled rate from the pump reservoir to the cylinder coupler.

To hold the load: Tighten the lock nut until it is snug against the top edge of the cylinder base. This will mechanically prevent the plunger from retracting when hydraulic pressure is relieved.

To loosen lock nut: Advance the plunger about 1/4 inch [6 mm] to remove any weight from the lock nut. Then, loosen the lock nut using a tommy bar of appropriate diameter.

To retract: Be sure that the locknut has been loosened a sufficient amount of turns, so that the plunger can be retracted

the desired amount. Then, operate pump and valve so that hydraulic oil is directed at a controlled rate from the cylinder coupler back to the pump reservoir.

Note that additional hydraulic components may be required to control the rate at which the plunger retracts under load.

NOTICE HCL-Series cylinders contain no plunger return spring. External force will be required to fully retract the plunger if it is not under load. Use of a hydraulic pump equipped with a vacuum valve will help aid plunger retraction.

9.0 INSPECTION, MAINTENANCE & STORAGE

- Periodically check the hydraulic system for loose connections leaks and obvious problems. Replace any damaged components immediately.
- Monitor the hydraulic oil temperature during operation. Do not exceed oil temperatures above 150°F [65°C].
- Install dust caps and plugs on all hydraulic couplings after the hydraulic hose is disconnected from the cylinder.
- Keep all hydraulic components clean.
- Periodically check that the orifice at the plunger stroke limiter port is free of dirt or other obstructions.
- Periodically check the tilt saddle (if equipped) for free movement. If required, disassemble, clean and lubricate the tilt saddle. Use white lithium grease.
- Change the hydraulic oil at the recommended interval shown in the pump instruction sheet. Change the oil immediately if contamination is suspected.
- Store cylinders in the vertical position, in a clean, dry and secure location. Keep stored cylinders and hoses away from heat and direct sunlight.
- If repairs are required, refer to the Enerpac website for the repair parts sheet applicable to your cylinder model.

NOTICE Hydraulic equipment must only be serviced by a qualified hydraulic technician. For repair service, contact the Enerpac Authorized Service Center in your area.

10.0 TROUBLESHOOTING

Refer to the troubleshooting guide when diagnosing cylinder operational problems. Please note that the troubleshooting guide is not all-inclusive, and should be considered only as an aid to help diagnose the most common possible problems.

For repair service, contact your nearest Enerpac Authorized Service Center. As required, also refer to the troubleshooting information provided with your hydraulic pump or power unit.

<i>Troubleshooting Guide</i>		
Symptom	Possible Cause	Solution
1. Plunger will not advance.	a. Pump release valve open.	Close pump release valve.
	b. Directional control valve not in proper position.	Shift directional control valve to proper position.
	c. Coupler not fully tightened.	Tighten coupler.
	d. Pump oil level is low.	Add oil to pump reservoir as required. See Section 6.2.
	e. Pump malfunctioning.	Repair or replace pump as required.
	f. Cylinder load rating too low for application.	Use a cylinder with a higher load rating.
	g. Cylinder seals leaking.	Repair or replace cylinder.
2. Plunger advances only part way.	a. Oil level in pump is low.	Add oil to pump reservoir as required. See Section 6.2.
	b. Coupler is not fully tightened.	Tighten coupler.
	c. Cylinder plunger binding.	Repair or replace cylinder.
3. Plunger advances erratically.	a. Air in hydraulic system.	Remove air from hydraulic system. See Section 6.5.
	b. Cylinder plunger binding.	Repair or replace cylinder.
4. Plunger advances more slowly than normal.	a. Leaking connection.	Repair leaking connection.
	b. Coupler not fully tightened.	Tighten coupler.
	c. Pump malfunctioning.	Repair or replace pump as required.
5. Plunger advances, but will not hold.	a. Pump malfunctioning.	Repair or replace pump as required.
	b. Leaking connection.	Repair leaking connection.
	c. Incorrect system set-up.	Check hose connections at pump and cylinders.
	d. Cylinder seals leaking.	Repair or replace cylinder.
6. Cylinder leaks oil.	a. Loose connection.	Tighten or repair connection.
	b. Oil flowing from plunger stroke limiter port. (plunger has exceeded maximum stroke)	Stop advancing plunger immediately when maximum stroke indicator line appears.
	c. Worn or damaged cylinder seals.	Repair or replace cylinder.
	d. Internal cylinder damage.	Repair or replace cylinder.
7. Plunger will not retract or retracts more slowly than normal.	a. Pump release valve closed.	Open pump release valve.
	b. Directional control valve not in proper position.	Shift directional control valve to proper position.
	c. Lock nut not loosened.	Loosen lock nut a sufficient amount of turns.
	d. Pump reservoir is overfilled.	Drain oil from pump reservoir as required.
	e. Improper hose connections.	Check hose connections.
	f. Narrow hose restricting oil flow.	Replace with larger diameter hose.
	g. Cylinder plunger binding and/or internal damage.	Repair or replace cylinder.

11.0 PRODUCT DATA

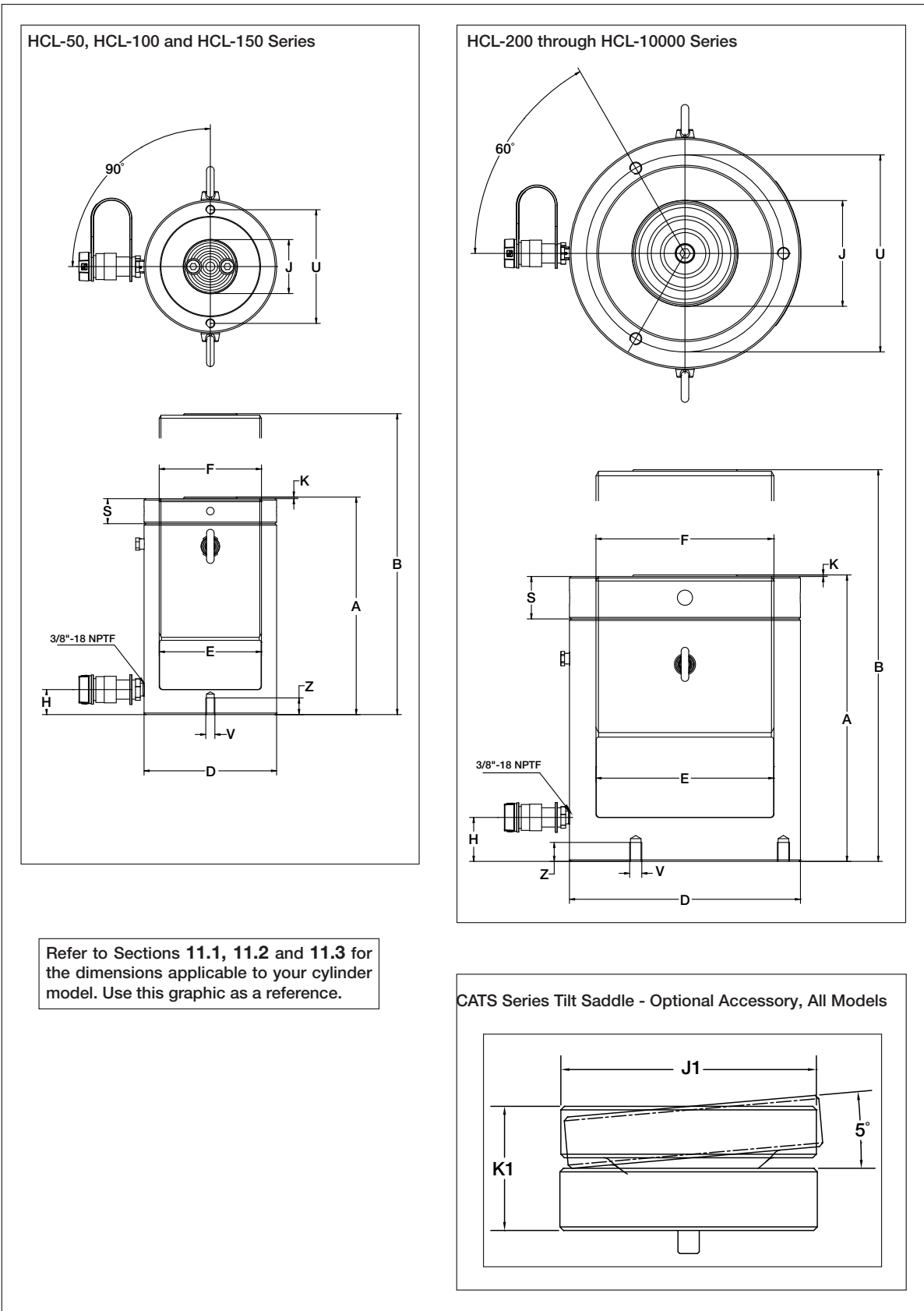

Figure 7, Dimensions - HCL-Series

Refer to Figure 7 for dimensions graphic.

11.1 Dimensions, HCL-Series (imperial)

Cylinder Model Number	Collapsed Height	Extended Height	Outside Diameter	Cyl. Bore Diameter	Plunger Diameter (threaded)	Base to Advance Port	Std. Saddle Diameter	Saddle Protrusion from Plunger	Lock Nut Height	Tilt Saddle (accessory)		
	A	B	D	E	F	H	J	K	S	Dia.	Height	Model No.
	in	in	in	in	mm	in	in	in	in	in	in	
HCL-502	6.46	8.43	5.12	3.94	TR 100 x 4	0.94	2.80	0.08	0.98	2.80	1.18	CATS-100
HCL-504	8.43	12.36	5.12	3.94	TR 100 x 4	0.94	2.80	0.08	0.98	2.80	1.18	CATS-100
HCL-506	10.39	16.30	5.12	3.94	TR 100 x 4	0.94	2.80	0.08	0.98	2.80	1.18	CATS-100
HCL-508	12.36	20.24	5.12	3.94	TR 100 x 4	0.94	2.80	0.08	0.98	2.80	1.18	CATS-100
HCL-5010	14.33	24.17	5.12	3.94	TR 100 x 4	0.94	2.80	0.08	0.98	2.80	1.18	CATS-100
HCL-5012	16.30	28.11	5.12	3.94	TR 100 x 4	0.94	2.80	0.08	0.98	2.80	1.18	CATS-100
HCL-1002	7.36	9.33	6.89	5.31	TR 135 x 6	1.30	2.80	0.08	1.30	2.80	1.18	CATS-100
HCL-1004	9.33	13.27	6.89	5.31	TR 135 x 6	1.30	2.80	0.08	1.30	2.80	1.18	CATS-100
HCL-1006	11.30	17.20	6.89	5.31	TR 135 x 6	1.30	2.80	0.08	1.30	2.80	1.18	CATS-100
HCL-1008	13.27	21.14	6.89	5.31	TR 135 x 6	1.30	2.80	0.08	1.30	2.80	1.18	CATS-100
HCL-10010	15.24	25.08	6.89	5.31	TR 135 x 6	1.30	2.80	0.08	1.30	2.80	1.18	CATS-100
HCL-10012	17.20	29.02	6.89	5.31	TR 135 x 6	1.30	2.80	0.08	1.30	2.80	1.18	CATS-100
HCL-1502	8.23	10.20	8.46	6.50	TR 165 x 6	1.61	5.12	0.08	1.57	4.96	1.69	CATS-201
HCL-1504	10.20	14.13	8.46	6.50	TR 165 x 6	1.61	5.12	0.08	1.57	4.96	1.69	CATS-201
HCL-1506	12.17	18.07	8.46	6.50	TR 165 x 6	1.61	5.12	0.08	1.57	4.96	1.69	CATS-201
HCL-1508	14.13	22.01	8.46	6.50	TR 165 x 6	1.61	5.12	0.08	1.57	4.96	1.69	CATS-201
HCL-15010	16.10	25.94	8.46	6.50	TR 165 x 6	1.61	5.12	0.08	1.57	4.96	1.69	CATS-201
HCL-15012	18.07	29.88	8.46	6.50	TR 165 x 6	1.61	5.12	0.08	1.57	4.96	1.69	CATS-201
HCL-2002	9.37	11.34	9.84	7.48	TR 190 x 6	1.85	5.12	0.08	1.77	4.96	1.69	CATS-201
HCL-2004	11.34	15.28	9.84	7.48	TR 190 x 6	1.85	5.12	0.08	1.77	4.96	1.69	CATS-201
HCL-2006	13.31	19.21	9.84	7.48	TR 190 x 6	1.85	5.12	0.08	1.77	4.96	1.69	CATS-201
HCL-2008	15.28	23.15	9.84	7.48	TR 190 x 6	1.85	5.12	0.08	1.77	4.96	1.69	CATS-201
HCL-20010	17.24	27.09	9.84	7.48	TR 190 x 6	1.85	5.12	0.08	1.77	4.96	1.69	CATS-201
HCL-20012	19.21	31.02	9.84	7.48	TR 190 x 6	1.85	5.12	0.08	1.77	4.96	1.69	CATS-201
HCL-2502	9.80	11.77	11.02	8.46	TR 215 x 6	2.09	5.49	0.08	2.05	6.89	2.70	CATS-300
HCL-2504	11.77	15.71	11.02	8.46	TR 215 x 6	2.09	5.49	0.08	2.05	6.89	2.70	CATS-300
HCL-2506	13.74	19.65	11.02	8.46	TR 215 x 6	2.09	5.49	0.08	2.05	6.89	2.70	CATS-300
HCL-2508	15.71	23.58	11.02	8.46	TR 215 x 6	2.09	5.49	0.08	2.05	6.89	2.70	CATS-300
HCL-25010	17.68	27.52	11.02	8.46	TR 215 x 6	2.09	5.49	0.08	2.05	6.89	2.70	CATS-300
HCL-25012	19.65	31.46	11.02	8.46	TR 215 x 6	2.09	5.49	0.08	2.05	6.89	2.70	CATS-300
HCL-3002	10.94	12.91	12.01	9.25	TR 235 x 6	2.28	5.49	0.08	2.20	6.89	2.70	CATS-300
HCL-3004	12.91	16.85	12.01	9.25	TR 235 x 6	2.28	5.49	0.08	2.20	6.89	2.70	CATS-300
HCL-3006	14.88	20.79	12.01	9.25	TR 235 x 6	2.28	5.49	0.08	2.20	6.89	2.70	CATS-300
HCL-3008	16.85	24.72	12.01	9.25	TR 235 x 6	2.28	5.49	0.08	2.20	6.89	2.70	CATS-300
HCL-30010	18.82	28.66	12.01	9.25	TR 235 x 6	2.28	5.49	0.08	2.20	6.89	2.70	CATS-300
HCL-30012	20.79	32.60	12.01	9.25	TR 235 x 6	2.28	5.49	0.08	2.20	6.89	2.70	CATS-300
HCL-4002	12.48	14.45	13.78	10.63	TR 270 x 6	2.64	6.27	0.20	2.56	8.27	3.07	CATS-400
HCL-4004	14.45	18.39	13.78	10.63	TR 270 x 6	2.64	6.27	0.20	2.56	8.27	3.07	CATS-400
HCL-4006	16.42	22.32	13.78	10.63	TR 270 x 6	2.64	6.27	0.20	2.56	8.27	3.07	CATS-400
HCL-4008	18.39	26.26	13.78	10.63	TR 270 x 6	2.64	6.27	0.20	2.56	8.27	3.07	CATS-400
HCL-40010	20.35	30.20	13.78	10.63	TR 270 x 6	2.64	6.27	0.20	2.56	8.27	3.07	CATS-400
HCL-40012	22.32	34.13	13.78	10.63	TR 270 x 6	2.64	6.27	0.20	2.56	8.27	3.07	CATS-400
HCL-5002	14.06	16.02	15.75	12.01	TR 305 x 6	2.95	7.06	0.20	2.83	9.06	3.07	CATS-500
HCL-5004	16.02	19.96	15.75	12.01	TR 305 x 6	2.95	7.06	0.20	2.83	9.06	3.07	CATS-500
HCL-5006	17.99	23.90	15.75	12.01	TR 305 x 6	2.95	7.06	0.20	2.83	9.06	3.07	CATS-500
HCL-5008	19.96	27.83	15.75	12.01	TR 305 x 6	2.95	7.06	0.20	2.83	9.06	3.07	CATS-500
HCL-50010	21.93	31.77	15.75	12.01	TR 305 x 6	2.95	7.06	0.20	2.83	9.06	3.07	CATS-500
HCL-50012	23.90	35.71	15.75	12.01	TR 305 x 6	2.95	7.06	0.20	2.83	9.06	3.07	CATS-500
HCL-6002	14.96	16.93	16.93	12.99	TR 330 x 6	3.19	7.65	0.20	3.15	9.84	3.27	CATS-600
HCL-6004	16.93	20.87	16.93	12.99	TR 330 x 6	3.19	7.65	0.20	3.15	9.84	3.27	CATS-600
HCL-6006	18.90	24.80	16.93	12.99	TR 330 x 6	3.19	7.65	0.20	3.15	9.84	3.27	CATS-600
HCL-6008	20.87	28.74	16.93	12.99	TR 330 x 6	3.19	7.65	0.20	3.15	9.84	3.27	CATS-600
HCL-60010	22.83	32.68	16.93	12.99	TR 330 x 6	3.19	7.65	0.20	3.15	9.84	3.27	CATS-600
HCL-60012	24.80	36.61	16.93	12.99	TR 330 x 6	3.19	7.65	0.20	3.15	9.84	3.27	CATS-600
HCL-8002	16.93	18.90	19.88	15.16	TR 385 x 6	3.74	8.83	0.20	3.54	10.83	3.41	CATS-800
HCL-8004	18.90	22.83	19.88	15.16	TR 385 x 6	3.74	8.83	0.20	3.54	10.83	3.41	CATS-800
HCL-8006	20.87	26.77	19.88	15.16	TR 385 x 6	3.74	8.83	0.20	3.54	10.83	3.41	CATS-800
HCL-8008	22.83	30.71	19.88	15.16	TR 385 x 6	3.74	8.83	0.20	3.54	10.83	3.41	CATS-800
HCL-80010	24.80	34.65	19.88	15.16	TR 385 x 6	3.74	8.83	0.20	3.54	10.83	3.41	CATS-800
HCL-80012	26.77	38.58	19.88	15.16	TR 385 x 6	3.74	8.83	0.20	3.54	10.83	3.41	CATS-800
HCL-10002	19.06	21.02	22.44	17.32	TR 440 x 6	4.33	9.81	0.20	4.13	11.81	4.22	CATS-1000
HCL-10004	21.02	24.96	22.44	17.32	TR 440 x 6	4.33	9.81	0.20	4.13	11.81	4.22	CATS-1000
HCL-10006	22.99	28.90	22.44	17.32	TR 440 x 6	4.33	9.81	0.20	4.13	11.81	4.22	CATS-1000
HCL-10008	24.96	32.83	22.44	17.32	TR 440 x 6	4.33	9.81	0.20	4.13	11.81	4.22	CATS-1000
HCL-100010	26.93	36.77	22.44	17.32	TR 440 x 6	4.33	9.81	0.20	4.13	11.81	4.22	CATS-1000
HCL-100012	28.90	40.71	22.44	17.32	TR 440 x 6	4.33	9.81	0.20	4.13	11.81	4.22	CATS-1000

Refer to Figure 7 for dimensions graphic.

11.2 Dimensions, HCL-Series (metric)

Cylinder Model Number	Collapsed Height	Extended Height	Outside Diameter	Cyl. Bore Diameter	Plunger Diameter (threaded)	Base to Advance Port	Std. Saddle Diameter	Saddle Protrusion from Plunger	Lock Nut Height	Tilt Saddle (accessory)		
	A	B	D	E	F	H	J	K	S	J1	K1	Model No.
	mm	mm	mm	mm	mm	mm	mm	mm	mm	mm	mm	
HCL-502	164	214	130	100	TR 100 x 4	24	71	2	25	71	30	CATS-100
HCL-504	214	314	130	100	TR 100 x 4	24	71	2	25	71	30	CATS-100
HCL-506	264	414	130	100	TR 100 x 4	24	71	2	25	71	30	CATS-100
HCL-508	314	514	130	100	TR 100 x 4	24	71	2	25	71	30	CATS-100
HCL-5010	364	614	130	100	TR 100 x 4	24	71	2	25	71	30	CATS-100
HCL-5012	414	714	130	100	TR 100 x 4	24	71	2	25	71	30	CATS-100
HCL-1002	187	237	175	135	TR 135 x 6	33	71	2	33	71	30	CATS-100
HCL-1004	237	337	175	135	TR 135 x 6	33	71	2	33	71	30	CATS-100
HCL-1006	287	437	175	135	TR 135 x 6	33	71	2	33	71	30	CATS-100
HCL-1008	337	537	175	135	TR 135 x 6	33	71	2	33	71	30	CATS-100
HCL-10010	387	637	175	135	TR 135 x 6	33	71	2	33	71	30	CATS-100
HCL-10012	437	737	175	135	TR 135 x 6	33	71	2	33	71	30	CATS-100
HCL-1502	209	259	215	165	TR 165 x 6	41	130	2	40	126	43	CATS-201
HCL-1504	259	359	215	165	TR 165 x 6	41	130	2	40	126	43	CATS-201
HCL-1506	309	459	215	165	TR 165 x 6	41	130	2	40	126	43	CATS-201
HCL-1508	359	559	215	165	TR 165 x 6	41	130	2	40	126	43	CATS-201
HCL-15010	409	659	215	165	TR 165 x 6	41	130	2	40	126	43	CATS-201
HCL-15012	459	759	215	165	TR 165 x 6	41	130	2	40	126	43	CATS-201
HCL-2002	238	288	250	190	TR 190 x 6	47	130	2	45	126	43	CATS-201
HCL-2004	288	388	250	190	TR 190 x 6	47	130	2	45	126	43	CATS-201
HCL-2006	338	488	250	190	TR 190 x 6	47	130	2	45	126	43	CATS-201
HCL-2008	388	588	250	190	TR 190 x 6	47	130	2	45	126	43	CATS-201
HCL-20010	438	688	250	190	TR 190 x 6	47	130	2	45	126	43	CATS-201
HCL-20012	488	788	250	190	TR 190 x 6	47	130	2	45	126	43	CATS-201
HCL-2502	249	299	280	215	TR 215 x 6	53	140	2	52	175	69	CATS-300
HCL-2504	299	399	280	215	TR 215 x 6	53	140	2	52	175	69	CATS-300
HCL-2506	349	499	280	215	TR 215 x 6	53	140	2	52	175	69	CATS-300
HCL-2508	399	599	280	215	TR 215 x 6	53	140	2	52	175	69	CATS-300
HCL-25010	449	699	280	215	TR 215 x 6	53	140	2	52	175	69	CATS-300
HCL-25012	499	799	280	215	TR 215 x 6	53	140	2	52	175	69	CATS-300
HCL-3002	278	328	305	235	TR 235 x 6	58	140	2	56	175	69	CATS-300
HCL-3004	328	428	305	235	TR 235 x 6	58	140	2	56	175	69	CATS-300
HCL-3006	378	528	305	235	TR 235 x 6	58	140	2	56	175	69	CATS-300
HCL-3008	428	628	305	235	TR 235 x 6	58	140	2	56	175	69	CATS-300
HCL-30010	478	728	305	235	TR 235 x 6	58	140	2	56	175	69	CATS-300
HCL-30012	528	828	305	235	TR 235 x 6	58	140	2	56	175	69	CATS-300
HCL-4002	317	367	350	270	TR 270 x 6	67	159	5	65	210	78	CATS-400
HCL-4004	367	467	350	270	TR 270 x 6	67	159	5	65	210	78	CATS-400
HCL-4006	417	567	350	270	TR 270 x 6	67	159	5	65	210	78	CATS-400
HCL-4008	467	667	350	270	TR 270 x 6	67	159	5	65	210	78	CATS-400
HCL-40010	517	767	350	270	TR 270 x 6	67	159	5	65	210	78	CATS-400
HCL-40012	567	867	350	270	TR 270 x 6	67	159	5	65	210	78	CATS-400
HCL-5002	357	407	400	305	TR 305 x 6	75	179	5	72	230	78	CATS-500
HCL-5004	407	507	400	305	TR 305 x 6	75	179	5	72	230	78	CATS-500
HCL-5006	457	607	400	305	TR 305 x 6	75	179	5	72	230	78	CATS-500
HCL-5008	507	707	400	305	TR 305 x 6	75	179	5	72	230	78	CATS-500
HCL-50010	557	807	400	305	TR 305 x 6	75	179	5	72	230	78	CATS-500
HCL-50012	607	907	400	305	TR 305 x 6	75	179	5	72	230	78	CATS-500
HCL-6002	380	430	430	330	TR 330 x 6	81	194	5	80	250	83	CATS-600
HCL-6004	430	530	430	330	TR 330 x 6	81	194	5	80	250	83	CATS-600
HCL-6006	480	630	430	330	TR 330 x 6	81	194	5	80	250	83	CATS-600
HCL-6008	530	730	430	330	TR 330 x 6	81	194	5	80	250	83	CATS-600
HCL-60010	580	830	430	330	TR 330 x 6	81	194	5	80	250	83	CATS-600
HCL-60012	630	930	430	330	TR 330 x 6	81	194	5	80	250	83	CATS-600
HCL-8002	430	480	505	385	TR 385 x 6	95	224	5	90	275	87	CATS-800
HCL-8004	480	580	505	385	TR 385 x 6	95	224	5	90	275	87	CATS-800
HCL-8006	530	680	505	385	TR 385 x 6	95	224	5	90	275	87	CATS-800
HCL-8008	580	780	505	385	TR 385 x 6	95	224	5	90	275	87	CATS-800
HCL-80010	630	880	505	385	TR 385 x 6	95	224	5	90	275	87	CATS-800
HCL-80012	680	980	505	385	TR 385 x 6	95	224	5	90	275	87	CATS-800
HCL-10002	484	534	570	440	TR 440 x 6	110	249	5	105	300	107	CATS-1000
HCL-10004	534	634	570	440	TR 440 x 6	110	249	5	105	300	107	CATS-1000
HCL-10006	584	734	570	440	TR 440 x 6	110	249	5	105	300	107	CATS-1000
HCL-10008	634	834	570	440	TR 440 x 6	110	249	5	105	300	107	CATS-1000
HCL-100010	684	934	570	440	TR 440 x 6	110	249	5	105	300	107	CATS-1000
HCL-100012	734	1034	570	440	TR 440 x 6	110	249	5	105	300	107	CATS-1000

Refer to Figure 7 for dimensions graphic.

11.3 Base Mounting Hole Information, HCL-Series

Cylinder Series	Base Mounting Holes						
	Bolt Circle		Thread Size	Minimum Thread Depth		Number of Holes	Angle From Coupler
	U		V	Z			
	in	mm	mm	in	mm		
HCL-50	4.13	105	M8 x 1.25	0.39	10	2	90°
HCL-100	5.91	150	M12 x 1.75	0.67	17	2	90°
HCL-150	7.28	185	M12 x 1.75	0.87	22	2	90°
HCL-200	8.46	215	M12 x 1.75	0.87	22	3	60°
HCL-250	9.65	245	M12 x 1.75	0.87	22	3	60°
HCL-300	10.24	260	M16 x 2	0.98	25	3	60°
HCL-400	11.81	300	M16 x 2	0.98	25	3	60°
HCL-500	13.39	340	M24 x 3	1.42	36	3	60°
HCL-600	14.57	370	M24 x 3	1.42	36	3	60°
HCL-800	17.32	440	M24 x 3	1.42	36	3	60°
HCL-1000	19.69	500	M24 x 3	1.42	36	3	60°

11.4 Specifications, HCL-Series



Pressure, capacity and stroke ratings are maximum safety limits. Good practice encourages using only 80% of these ratings

Cylinder Model Number	Stroke		Cylinder Class	Maximum Capacity			Effective Area		Oil Capacity		Weight	
	in	mm		US Ton	Tonnes	kN	in ²	cm ²	in ³	cm ³	lb	Kg
HCL-502	1.97	50	50	62	56	550	12.17	78.5	23.96	393	37	17
HCL-504	3.94	100	50	62	56	550	12.17	78.5	47.93	785	48	22
HCL-506	5.91	150	50	62	56	550	12.17	78.5	71.89	1178	60	27
HCL-508	7.87	200	50	62	56	550	12.17	78.5	95.86	1571	71	32
HCL-5010	9.84	250	50	62	56	550	12.17	78.5	119.82	1963	83	38
HCL-5012	11.81	300	50	62	56	550	12.17	78.5	143.78	2356	94	43
HCL-1002	1.97	50	100	113	102	1002	22.19	143.1	43.67	716	77	35
HCL-1004	3.94	100	100	113	102	1002	22.19	143.1	87.35	1431	98	44
HCL-1006	5.91	150	100	113	102	1002	22.19	143.1	131.02	2147	118	54
HCL-1008	7.87	200	100	113	102	1002	22.19	143.1	174.70	2863	139	63
HCL-10010	9.84	250	100	113	102	1002	22.19	143.1	218.37	3578	160	73
HCL-10012	11.81	300	100	113	102	1002	22.19	143.1	262.05	4294	181	82
HCL-1502	1.97	50	150	168	153	1497	33.14	213.8	65.24	1069	130	59
HCL-1504	3.94	100	150	168	153	1497	33.14	213.8	130.48	2138	161	73
HCL-1506	5.91	150	150	168	153	1497	33.14	213.8	195.73	3207	192	87
HCL-1508	7.87	200	150	168	153	1497	33.14	213.8	260.97	4276	224	102
HCL-15010	9.84	250	150	168	153	1497	33.14	213.8	326.21	5346	255	116
HCL-15012	11.81	300	150	168	153	1497	33.14	213.8	391.45	6415	287	130
HCL-2002	1.97	50	200	223	202	1985	43.95	283.5	86.51	1418	188	85
HCL-2004	3.94	100	200	223	202	1985	43.95	283.5	173.02	2835	231	105
HCL-2006	5.91	150	200	223	202	1985	43.95	283.5	259.53	4253	273	124
HCL-2008	7.87	200	200	223	202	1985	43.95	283.5	346.04	5671	316	143
HCL-20010	9.84	250	200	223	202	1985	43.95	283.5	432.55	7088	358	163
HCL-20012	11.81	300	200	223	202	1985	43.95	283.5	519.06	8506	401	182
HCL-2502	1.97	50	250	286	259	2541	56.27	363.1	110.77	1815	262	119
HCL-2504	3.94	100	250	286	259	2541	56.27	363.1	221.55	3631	316	143
HCL-2506	5.91	150	250	286	259	2541	56.27	363.1	332.32	5446	369	167
HCL-2508	7.87	200	250	286	259	2541	56.27	363.1	443.09	7261	422	192
HCL-25010	9.84	250	250	286	259	2541	56.27	363.1	553.87	9076	476	216
HCL-25012	11.81	300	250	286	259	2541	56.27	363.1	664.64	10892	529	240
HCL-3002	1.97	50	300	341	310	3036	67.23	433.7	132.34	2169	348	158
HCL-3004	3.94	100	300	341	310	3036	67.23	433.7	264.68	4337	411	186
HCL-3006	5.91	150	300	341	310	3036	67.23	433.7	397.02	6506	474	215
HCL-3008	7.87	200	300	341	310	3036	67.23	433.7	529.36	8675	537	244
HCL-30010	9.84	250	300	341	310	3036	67.23	433.7	661.71	10843	601	272
HCL-30012	11.81	300	300	341	310	3036	67.23	433.7	794.05	13012	664	301
HCL-4002	1.97	50	400	450	409	4008	88.75	572.6	174.70	2863	520	236
HCL-4004	3.94	100	400	450	409	4008	88.75	572.6	349.39	5726	603	274
HCL-4006	5.91	150	400	450	409	4008	88.75	572.6	524.09	8588	686	311
HCL-4008	7.87	200	400	450	409	4008	88.75	572.6	698.79	11451	770	349
HCL-40010	9.84	250	400	450	409	4008	88.75	572.6	873.49	14314	853	387
HCL-40012	11.81	300	400	450	409	4008	88.75	572.6	1048.18	17177	936	425
HCL-5002	1.97	50	500	575	522	5114	113.25	730.6	222.92	3653	751	341
HCL-5004	3.94	100	500	575	522	5114	113.25	730.6	445.85	7306	860	390
HCL-5006	5.91	150	500	575	522	5114	113.25	730.6	668.77	10959	968	439
HCL-5008	7.87	200	500	575	522	5114	113.25	730.6	891.70	14612	1077	489
HCL-50010	9.84	250	500	575	522	5114	113.25	730.6	1114.62	18265	1186	538
HCL-50012	11.81	300	500	575	522	5114	113.25	730.6	1337.55	21918	1294	587
HCL-6002	1.97	50	600	673	611	5987	132.57	855.3	260.97	4276	942	427
HCL-6004	3.94	100	600	673	611	5987	132.57	855.3	521.94	8553	1067	484
HCL-6006	5.91	150	600	673	611	5987	132.57	855.3	782.90	12829	1193	541
HCL-6008	7.87	200	600	673	611	5987	132.57	855.3	1043.87	17106	1319	598
HCL-60010	9.84	250	600	673	611	5987	132.57	855.3	1304.84	21382	1444	655
HCL-60012	11.81	300	600	673	611	5987	132.57	855.3	1565.81	25659	1570	712
HCL-8002	1.97	50	800	916	831	8149	180.44	1164.2	355.21	5,821	1472	668
HCL-8004	3.94	100	800	916	831	8149	180.44	1164.2	710.41	11642	1646	746
HCL-8006	5.91	150	800	916	831	8149	180.44	1164.2	1065.62	17462	1819	825
HCL-8008	7.87	200	800	916	831	8149	180.44	1164.2	1420.82	23283	1992	904
HCL-80010	9.84	250	800	916	831	8149	180.44	1164.2	1776.03	29104	2166	982
HCL-80012	11.81	300	800	916	831	8149	180.44	1164.2	2131.24	34925	2339	1061
HCL-10002	1.97	50	1000	1196	1085	10644	235.68	1520.5	463.94	7603	2115	959
HCL-10004	3.94	100	1000	1196	1085	10644	235.68	1520.5	927.88	15205	2335	1059
HCL-10006	5.91	150	1000	1196	1085	10644	235.68	1520.5	1391.83	22808	2556	1160
HCL-10008	7.87	200	1000	1196	1085	10644	235.68	1520.5	1855.77	30411	2777	1260
HCL-100010	9.84	250	1000	1196	1085	10644	235.68	1520.5	2319.71	38013	2998	1360
HCL-100012	11.81	300	1000	1196	1085	10644	235.68	1520.5	2783.65	45616	3219	1460

