

## Air Chain Hoists | 50 Ton | NM50TI Model | Hook Top

Model  
NM50TI

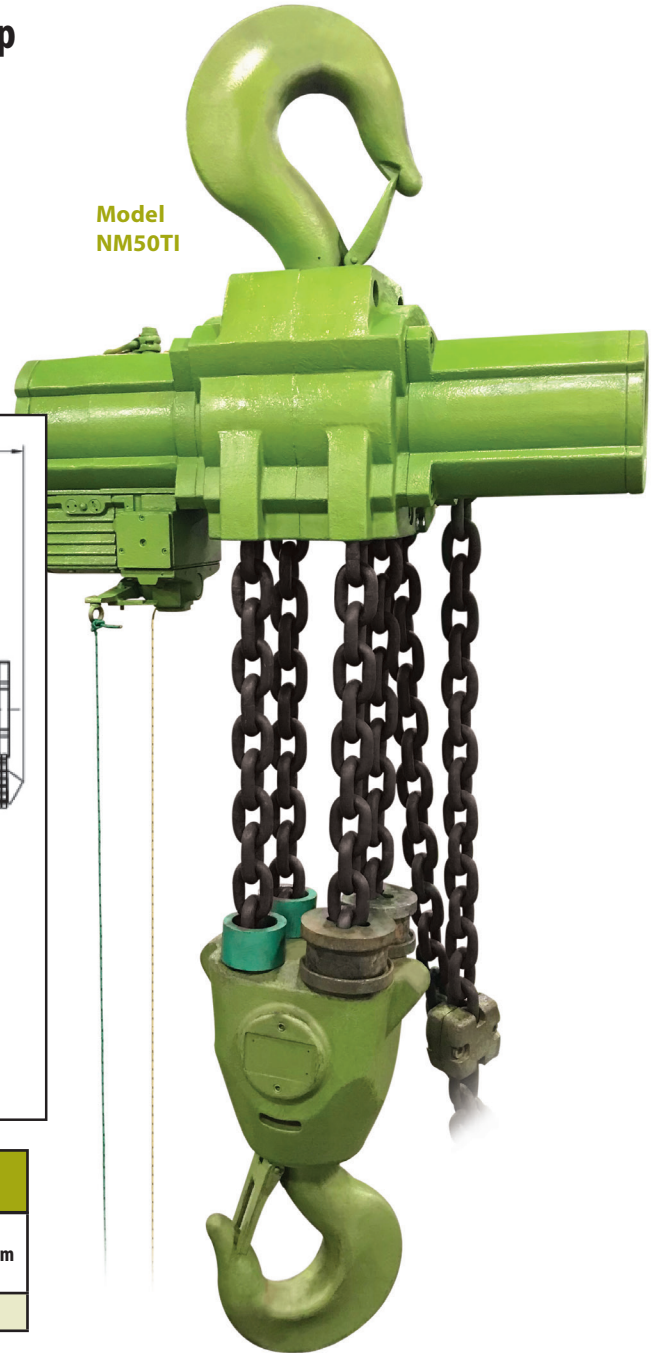
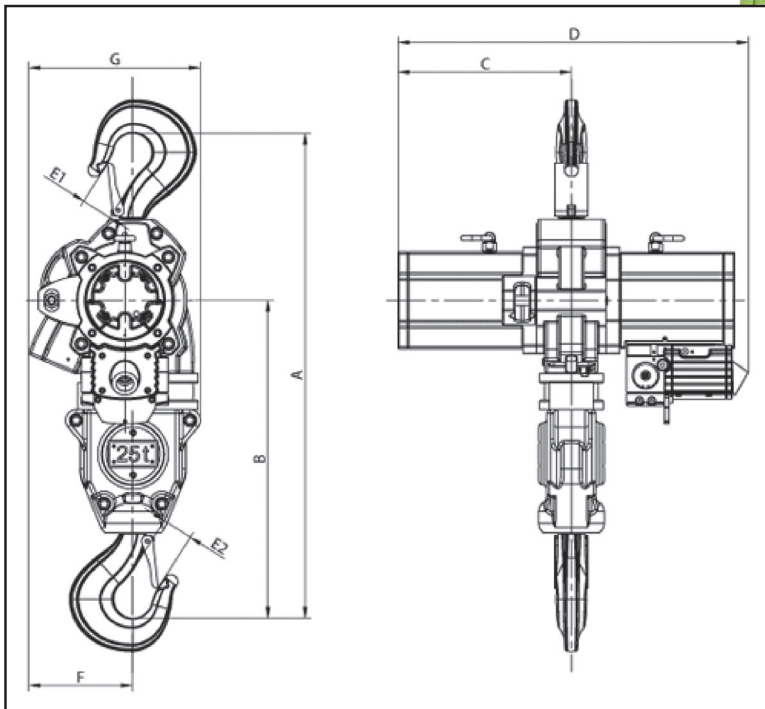

### Dimensions

Model	A*	B	C	D	E1	E2	F	G Maximum Width
NM50TI	68.7	46.8	21.2	44.3	4.1	4.1	7.1	19.3

Green shading reflects rental inventory.

\* Chain containers increase the headroom.

### Specifications

Model	Air Pressure (PSI Bar)	Capacity (Tons)	Number of Chain Strands	Motor Output (kW)	Lifting Speed Without Load (ft/min)	Lifting Speed at Full Load (ft/min)	Lowering Speed at Full Load (ft/min)	Air Consumption at Full Load - Lifting (cfm)	Air Consumption at Full Load - Lowering (cfm)	Air Connection (inch)	Hose Dimension (Ø Inside) (inch)	Weight (lbs.)	Chain Dimension (mm)	Weight of 1 meter (3.28 ft) Chain (lbs./ft.)	Standard Lift (ft)	Length of Control at Standard Lift (ft)	Sound Level at Full Load - Lifting dB(A)	Sound Level at Full Load - Lowering dB(A)
NM50TI	85	50	4	10	4.27	2.3	5.25	388	434	1.5	1.375	1960	22 x 66	7.25	10	6.5	88	89

Green shading reflects rental inventory.